



OPERATOR'S HANDBOOK
WOODBURNING PROFESSIONAL OVEN
"VESUVIO" MOD. GR



La Bottega Toscana



VALORIANI'S Factory nel 1900



First of all we wish to thank you for selecting a professional oven of the "VESUVIO" line and we congratulate you on your choice.

Our company has manufactured refractory items and PREFABRICATED ovens for over 50 years in our premises located in Reggello, close to Florence. All items produced spring from an idea that Mr. SILVIO VALORIANI had right after World Word II for bread baking.

The concept immediately met the favour of the Italian people and proved to be the winning card of the company. Thanks to their easy assembly, installation and use, these ovens are used to cook many traditional dishes, such as lasagne, roasts, baked pasta, besides of course bread and PIZZA

The special design of the vault in refractory *cotto* perfectly matches the cooking surface made up of elements in REFRACTORY COTTO.

This way our ovens offer the same – or even improved, we may add – features of old wood-fired ovens, which were built with refractory bricks laid down following a special design according to ancient building techniques, whose origins are lost in the mists of time.

Massimo Valoriani

CONTENTS

PART A SUGGESTIONS FOR THE ARRANGEMENT OF THE SUOOPRT FLOOR

PART B ASSEMBLING SCHEME OF THE OVEN

PART C UPPER THERMAL INSULATION OF THE OVEN

PART D FIRST OVEN'S FIRING

PART E FIRE'SPOSITION AND WOOD'S USE – DIRECTIONS FOR THE USE

PART F BAKING TIMES

PART G CLEANING AND MAINTENANCE



PART A

SUGGESIONS FOR THE ARRANGEMENT OF THE SUPPORT FLOOR :

- Build a solid base according to the size of the oven you've chosen. Concerning the sizes and shapes you can take a hint from the dates and drawings quoted in the figure and schedule 1.1
- As building material we suggest to use hollow tiles, while we do not absolutely suggest the use of reinforced concrete which could take the heat away from the oven.
- We remind you to check with a level the perfect leveling of the floor you're building.
- Once completed the building of the load bearing structure, build a tank with an height of cm. 20 by using hollow tiles or cellular silicate calcium.

Please find some examples of insulation's floors: :

Round base suitable for the ovens : 100-120-140-180.

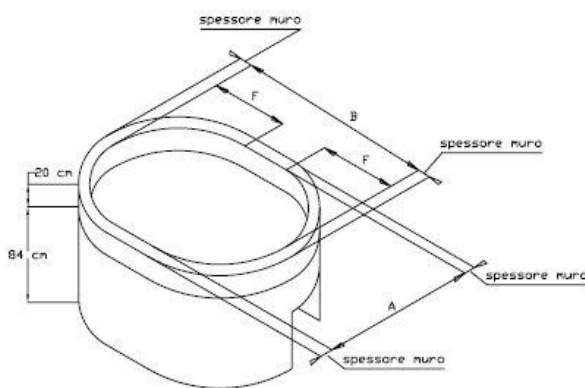
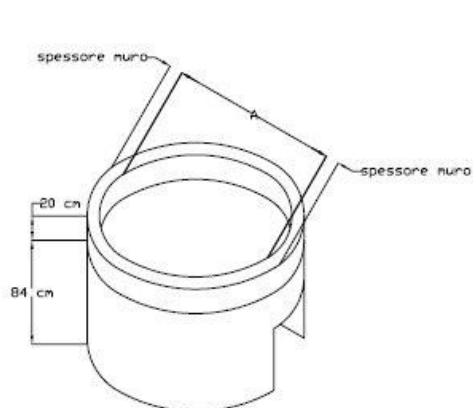

Oval base suitable for the ovens 120x160 140x160 140x180

Standard base suitable for all the ovens .

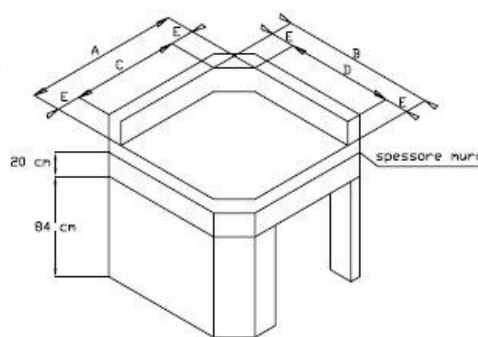
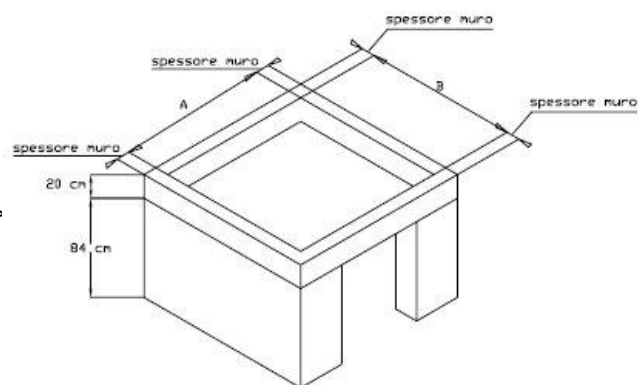

Small base suitable for all the ovens in case of very small spaces

FIGURE AND SCHEDULE 1.1	A	B	C	D	E	F	Load of the floor
Oven 100	140	140	60	60	40	\	2000 Kg
Oven 120	160	160	100	100	30	\	2400 Kg
Oven 140	180	180	150	150	30	\	2600 Kg
Oven 120x160	160	200	\	\	\	40	2600 Kg
Oven 140x160	180	200	\	\	\	50	2800 Kg
Oven 140x180	180	220	\	\	\	50	3000 Kg
Oven 180	220	220	\	\	\	50	3400 Kg

TO THE MEASURES INDICATED IN FIGURE AND SCHEDULE 1.1. ADD THE THICKNESS OF THE CURTAIN WALLS



- Fill carefully the tank with bloks of cellular silicate calcium , by creating in this way a solid and uniform layer; pay attention not to leave empty spaces and check that the floor does not move. **Do not mason the blocks but stuff them carefully , so that they result firmly fixed.**
- We remind you that you can shape the silicate blocks by using a normal saw.
- Carefully chech that the floor you've built is perfectly horizontal and does not present any disconnectedness. In case you should correct eventual uneveness you can use rasps to rasp carefully the floor.
- Once completed the floor brush it carefully in order to remove dusts and residula products. Please always check not to dampen the insulation floor.

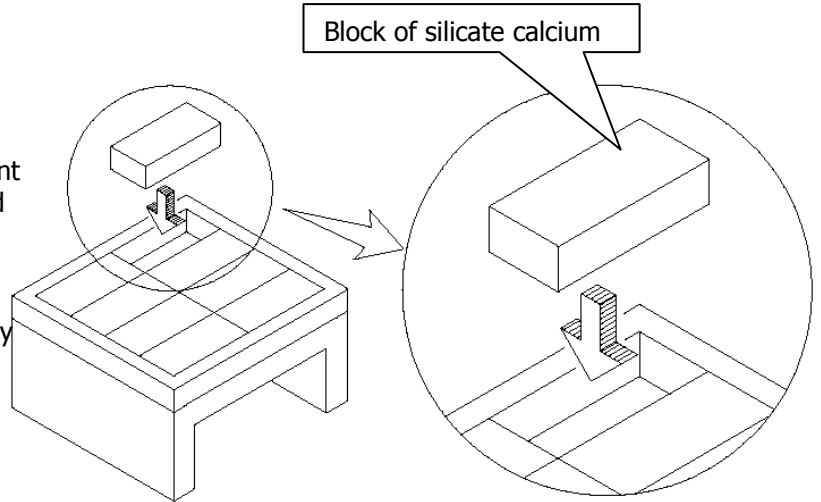

• You can find the silicate calcium by our Factory, as shown in our insulation's kit

IMPORTANT

PAY ALWAYS THE MAXIMUM ATTENTION DURING THE CARRYING OUT OF THE OPERATIONS DESCRIBED;
THE CORRECT BUILDING OF A GOOD INSULATION FLOOR IS THE GROUNDING FOR THE GOOD WORKING
AND DURAATION OF THE OVEN.

REFRATTARI VALORIANI DOES NOT ASSUME ANY RESPONSIBILITY OF CHECK OR INSPECTION OF THE
OPEARATIONS DESCRIBED IN THIS HANDBOOK.



Part B : ASSEMBLING OF THE OVEN'S BODY

THE PROFESSIONAL OVEN "VESUVIO" CAN BE EASILY ASSEMBLED IN FEW HOURS. EXECUTE THE OPERATIONS STEPS, BY FOLLOWING THE BELOW DESCRIBED ORDER AND REFERRING TO THE SCHEME 2 ACCORDING TO YOUR OVEN'S SIZE.

- 1) PLACE THE FRONT ELEMENT A . CLEAN CAREFULLY ALL THE FLOOR.

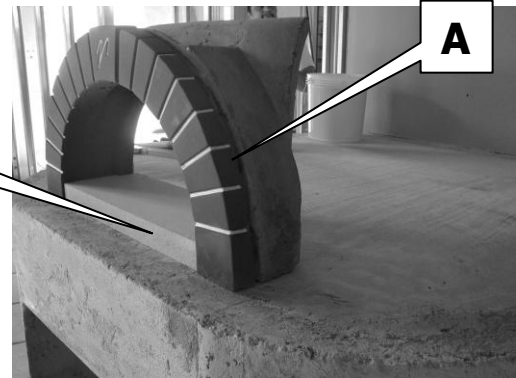

Piece N. 1

- 2) PLACE WITHOUT GLUING IT, THE PIECE N°1. IT'S IMPORTANT TO PAY ATTENTION TO THE RIGHT POSITIONING OF THIS FIRST ELEMENT, BECAUSE ALL THE ASSEMBLY WILL HAPPEN CONSEQUENTLY.

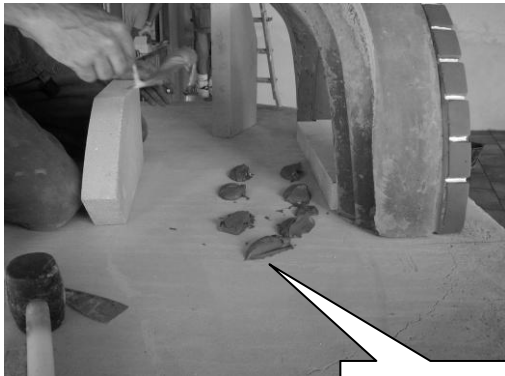

- 3) PLACE THE FLOOR'S ELEMENTS MADE OF REFRACTORY COTTO FOLLOWING THE SEQUENCE IN THE SCHEME 2 PAGE 7, 8, 9, ACCORDING TO THE OVEN CHOSEN.

- 4) USE THE REFRACTORY MORTAR VALORIANI VALPLAST TO GIVE THICKNESS TO THE FLOOR'S TILES AND GLUE THEM.

- 5) HIT WITH A RUBBER HAMMER UNTIL OBTAINING A PERFECT LEVELING OF THE FLOOR, ALWAYS CHECK WITH THE LEVEL.



- 6) REMOVE EVENTUAL RESIDUAL PRODUCTS AND DUST BEFORE ASSEMBLING ANOTHER FLOOR TILE

- 7) WHILE PROCEEDING WITH THE ASSEMBLY ALWAYS CHECK THE LINING OF THE FLOOR'S TILES

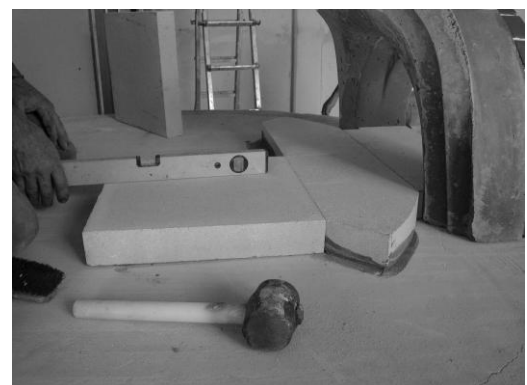



8) That's how an oven's floor must result after the work .

WARNING

TO PLACE THE CROWN'S ELEMENTS THE OPERATOR MAY NEED TO STAMP ON THE FLOOR, IN THAT CASE PLACE SOME WOODEN AXES ON IT, IN ORDER NOT TO COMPROMISE ITS PLANARITY

9) PLACE DRY THE CROWN'S ELEMENTS IN THE ORDER SHOWN IN THE SCHEME 2



VALPLAST

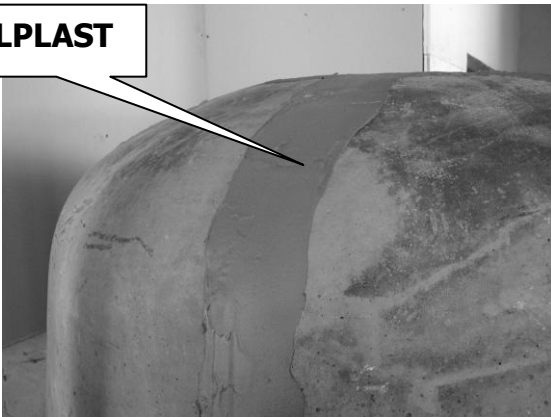

ACCORDING TO THE OVEN CHOSEN.

10) THE CROWN'S ELEMENTS MUST BE STUCCOED **ONLY** EXTERNALLY WITH REFRACTORY PLASTIC MORTAR VALPLAST

11) BEFORE INSERTING THE FLUE MANIFOLD, LAY SOME MORTAR VALPLAST ON THE LEDGE IN ORDER TO CREATE THE GASKET. THE HOLES ON THE TWO SIDE FLANGES ALLOW THE INSERTION OF THE SUITABLE DOWELS AFTER DRILLING THE OVEN'S MOUTH.

Flue manifold

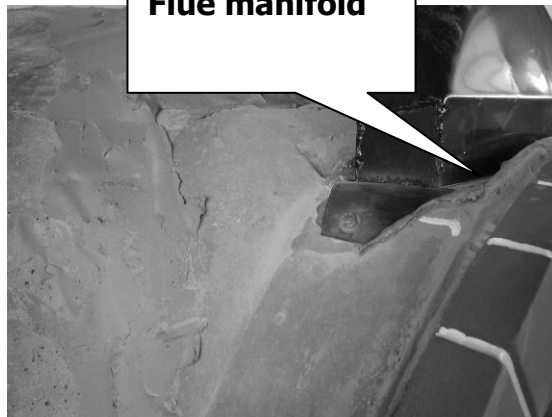

IMPORTANT

WITH REFERENCE TO THE CHIMNEY FLUE THIS ONE MUST BE INSTALLED FROM QUALIFIED PERSONNEL IN CONFORMITY WITH THE NORMS **UNI 9615**.

THE OUTLET DIAMETR OF THE FLUE MANIFOLD IS 20 CM



SCHEME 2 ASSEMBLING OF THE FLOOR'S TILES AND OVEN'S CROWNS

GR 100

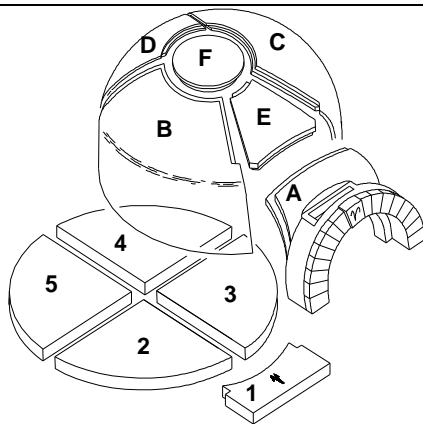

PLACE DRY THE CROWN'S ELEMENTS IN THE FOLLOWING ORDER:

- APPROACH THE SIDE ELEMENTS B AND C
- APPROACH THE BACK ELEMENT D
- OVERLAP THE ELEMENT E
- BEFORE INSERTING THE UPPER ELEMENT, APPLY SOME VALPLAST, TO CREATE A PERFECT SEAL, THEN INSTALL THE KEYSTONE F, AFTER HAVING CAREFULLY CHECKED THE PERFECT INSTALLATION OF THE OTHER PARTS.

GR 120

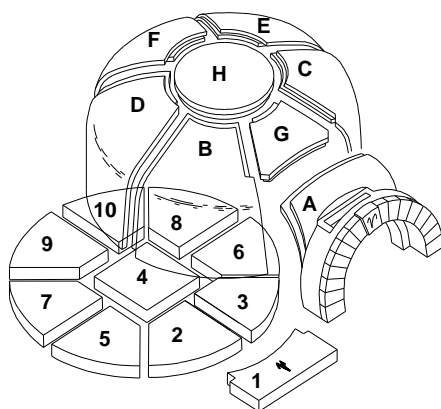

PLACE DRY THE CROWN'S ELEMENTS IN THE FOLLOWING ORDER:

- APPROACH THE REMAINING SIDE ELEMENTS D AND E
- APPROACH THE BACK ELEMENT F
- OVERLAP THE ELEMENT G
- BEFORE INSERTING THE UPPER ELEMENT, APPLY SOME VALPLAST, TO CREATE A PERFECT SEAL, THEN INSTALL THE KEYSTONE H, AFTER HAVING CAREFULLY CHECKED THE PERFECT INSTALLATION OF THE OTHER PARTS.

GR 120x160

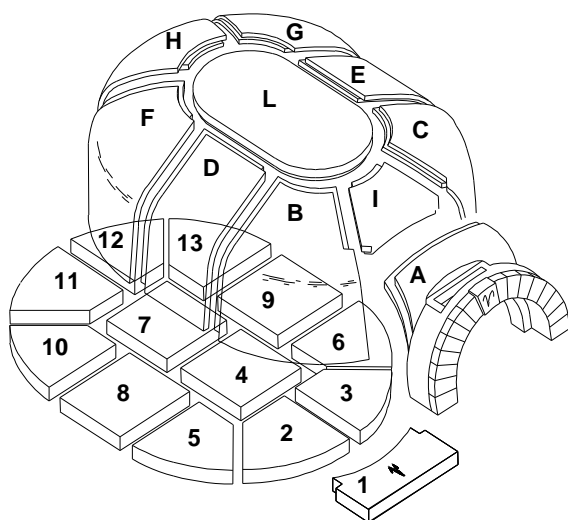

PLACE DRY THE CROWN'S ELEMENTS IN THE FOLLOWING ORDER:

- APPROACH THE SIDE ELEMENTS B AND C
- APPROACH THE REMAINING SIDE ELEMENTS D-E-F-G-
- APPROACH THE BACK ELEMENT H
- OVERLAP THE ELEMENT I
- BEFORE FITTING THE UPPER ELEMENT, APPLY SOME VALPLAST, TO CREATE A PERFECT SEAL, THEN INSTALL THE OVAL KEYSTONE L, AFTER HAVING CAREFULLY CHECKED THE PERFECT INSTALLATION OF



THE OTHER PARTS.

GR 140

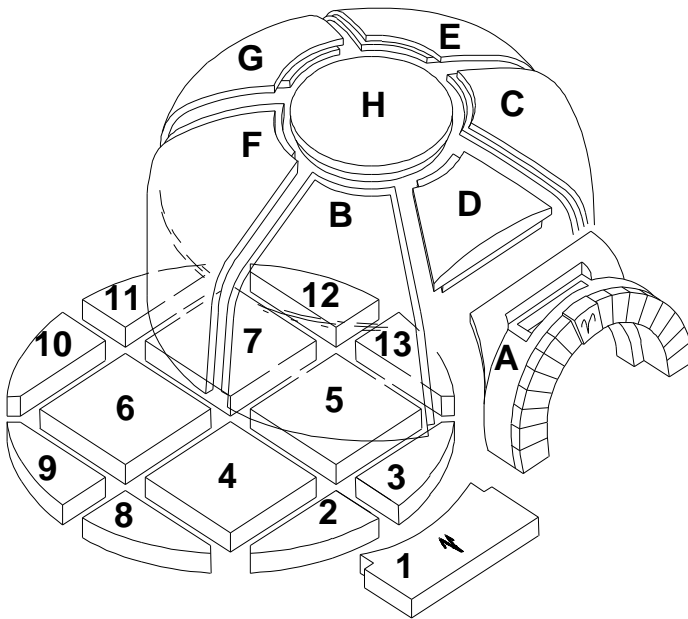

PLACE DRY THE CROWN'S ELEMENTS IN THE FOLLOWING ORDER:

- APPROACH THE SIDE ELEMENTS B AND C
- OVERLAP THE ELEMENT D
- APPROACH THE REMAINING SIDE ELEMENTS E-F
- APPROACH THE BACK ELEMENT G
- BEFORE INSERTING THE UPPER ELEMENT, APPLY SOME VALPLAST, TO CREATE A PERFECT SEAL, THEN INSTALL THE KEYSTONE H, AFTER HAVING CAREFULLY CHECKED THE PERFECT INSTALLATION OF THE OTHER PARTS.

GR 140x160

PLACE DRY THE CROWN'S ELEMENTS IN THE FOLLOWING ORDER:

- APPROACH THE SIDE ELEMENTS B AND C
- OVERLAP THE ELEMENT D
- APPROACH THE REMAINING SIDE ELEMENTS E-F-G-H
- APPROACH THE BACK ELEMENT I
 - BEFORE INSERTING THE UPPER ELEMENT, APPLY SOME VALPLAST, TO CREATE A PERFECT SEAL, THEN INSTALL

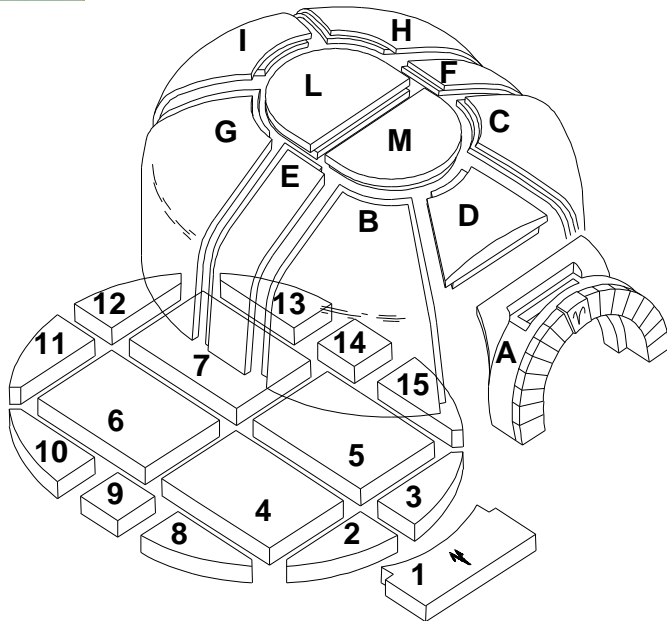

THE KEYSTONE L AND M, AFTER HAVING CAREFULLY CHECKED THE PERFECT INSTALLATION OF THE OTHER PARTS.

GR 140x180

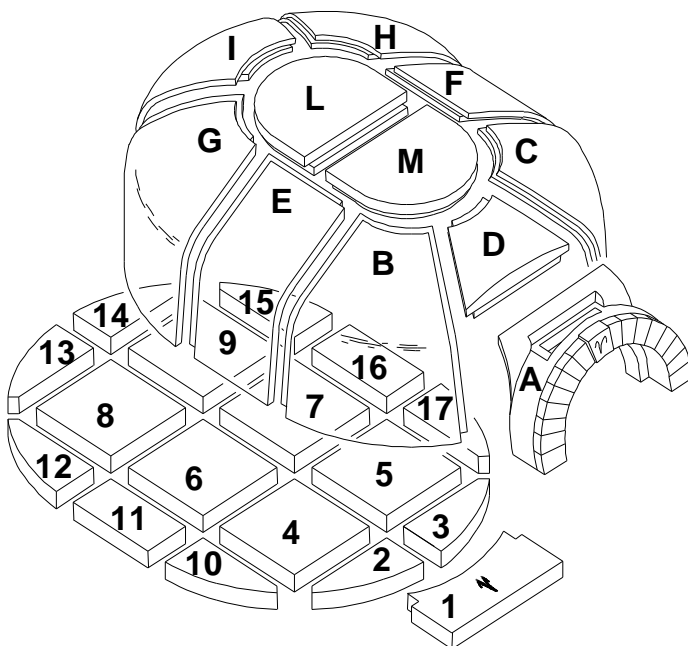

PLACE DRY THE CROWN'S ELEMENTS IN THE FOLLOWING ORDER:
 - APPROACH THE SIDE ELEMENTS B AND C
 -OVERLAP THE ELEMENT D
 -APPROACH THE REMAINING SIDE ELEMENTS E-F-G-H
 -APPROACH THE BACK ELEMENT I
 - BEFORE INSERTING THE UPPER ELEMENT, APPLY SOME VALPLAST, TO CREATE A PERFECT SEAL, THEN INSTALL THE KEYSTONE L AND M, AFTER HAVING CAREFULLY CHECKED THE PERFECT INSTALLATION OF THE OTHER PARTS

GR 180

PLACE DRY THE CROWN'S ELEMENTS IN THE FOLLOWING ORDER:
 - APPROACH THE SIDE ELEMENTS B AND C
 -OVERLAP THE ELEMENT D

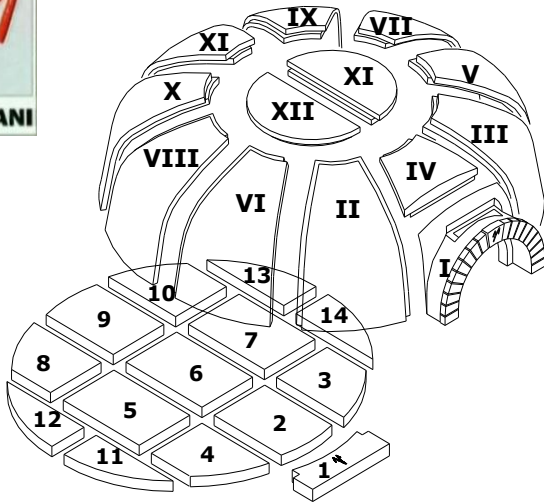

- APPROACH THE REMAINING SIDE ELEMENTS E-F-G-H
- PLACE THE LAST ELEMENT I
- BEFORE INSERTING THE UPPER ELEMENT, APPLY SOME VALPLAST, TO CREATE A PERFECT SEAL, THEN INSTALL THE KEYSTONE L AND M, AFTER HAVING CAREFULLY CHECKED THE PERFECT INSTALLATION OF THE OTHER PARTS

Part C UPPER INSULATION OF THE OVEN



12) ONCE COMPLETED THE STOCOING OF THE CROWN'S ELEMENTS, WRAP THE OVEN WITH A DOUBLE LAYER OF CERAMIC BLANKET.

13) LIFT THE PERIMETRAL WALLS OF THE OVEN. WE SUGGEST TO USE HOLLOW TILES. WE REMIND YOU THAT ANY WEIGHT MUST BURDEN UPON THE ARCH OF THE OVEN.

14) FILL WITH VERMICULITE UNTIL REACHING AN HEIGHT OF 25 CM. UPON THE OVEN'S TOP, COVERED WITH CERAMIC BLANKET. YOU SHOULD NOT FIND SUCH A METIERAL, YOU CAN REPLACE IT WITH EXPANDED CLAY WITH MEDIUM GRAINS.

DO NOT SEAL HERMETICALLY THE UPPER PART-Leave at least 2 air intakes 30x40

FILL WITH VERMICULITE VALORIANI.

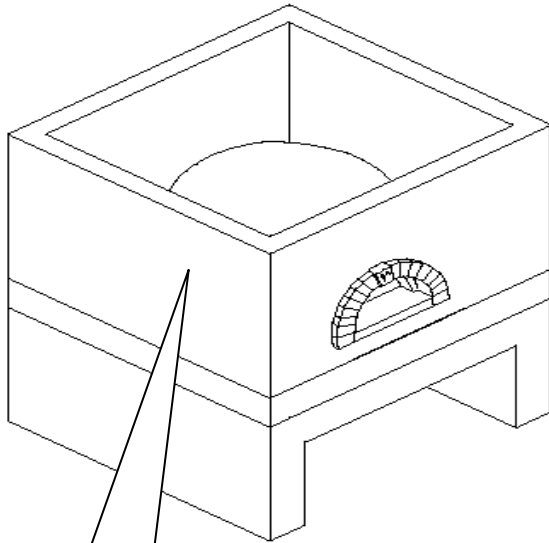

Perimetral walls.

- 15) LEAVE IN THE UPPER PART OF THE WALLS SOME AIR INTAKES FOR TRANSPIRATION, SO THAT THE OVEN COULD DISCHARGE THE DAMPNESS.

PART D OVEN'S FIRING

The oven when it's new, has a big water's content, which during the drying must not turn into steam inside the handwork.

Therefore it's **NECESSARY** to start very carefully with the first firing in order to avoid the above mentioned effect, which could create cracks to the handwork.

For **THE FIRST FIRING**, which has to be carried out gradually and constantly for 1 week days, we suggest you to follow these instructions:

- 1) Light a little the fire in the central part of the oven.
- 2) Keep an even inside temperature to about 150 C° CONSTANTLY for the first two days
- 3) Raise of 50 C° from the third day, for each day (**and keep it constant for all the day**); only at the fifth/sixth day the crown could turn into white colour and you could make the first baking tests.

IMPORTANT

LITTLE AND EVENTUAL CRACKS INSIDE THE CROWN'S ELEMENTS ARE PERFECTLY NORMAL AND ARE DUE TO THE THERMAL EXPANSION OF THESE ONES TO THE HIGH TEMPERATURES . SUCH CRACKS DO NOT COMPROMISE IN ANY WAY THE WORKING OF THE OVEN, THEY ARE SYMPTOMS OF A DEHUMIDIFICATION OF THE HANDWORK. BETWEEN THE FLOOR'S TILE AND THE CROWN'S ELEMENTS, A LITTLE SPACE IS WILLINGLY LEFT WHICH WILL BE FILLED BY THE USER DURING THE WORKING, WITH THE COMMON ASH. THIS OPERATION ALLOWS A THERMAL EXPANSION TO THE FLOOR, IN ORDER FOR IT NOT TO BEAT AGAINST THE CROWN'S ELEMENTS.



IMPORTANT

IN CASE OF AN EXTENDED INACTIVITY OF THE OVEN, PROCEED WITH A SLOW RELIGHTING FOR ABOUT 24/36 HOURS

IMPORTANT

WE RECOMMEND TO FOLLOW CAREFULLY WHAT ABOVE INDICATED, SINCE THE ALMOST TOTALITY OF THE CRACKS ON THE CROWN'S ELEMENTS OCCUR DUE TO A TOO FAST DRYING.

PART E - **FIRE'S POSITION AND WOOD'S USE**

With a normal oven's utilisation the fire should be positioned sideways; as the part most exposed to the fire will suffer consequently the most thermal expansions and the most wear during the years.

We recommend to alternate the fire from the right side to the left side and vice-versa; in this way you will obtain a constant balance for the structure and surely a better yield in time.

We suggest to use thin, light and dry wood, to make easier the fire's lighting and a better initial heating.

Successively, in order to have an optimum yield with a low wood consumption, we suggest to **use heavier and thicker wood** (Oak - Beech – Oliva in trunks long cm 30-40), by observing the quantities shown in our brochure.

We don't suggest the use of resinous wood.

Do not use any other kind of fuel, such as coal, charcoal slak, petrols, an so on.

The wood oput into the oven must NEVER be beaten against the crown because at high temperatures some damages to the structure may occur.



PART F **COOKING TIMES**

The cooking times are very variable; normally from 1,5 to 3,5 minutes for the traditional pizza, and are due to the kind of dough and to the inside temperature employed from each single pizzaman. One of the most important performance of our Vesuvio ovens is just the uniform backing capacity even in stressing working conditions. The perfect balance between the crown and the floor and the special refractory "cotto clay" contained in the floor enable an optimal backing, both slow at low temperature (250/300 C) and fast and high temperature (over 400 C without that the pizza dough sticks or burns.

PART G - INSIDE CLEANING AND MAINTENANCE

We suggest to use the suitable brass brushes for the inside cleaning of the oven, which you can easily find in commerce or at Refrattari Valoriani and **not to beat the shovel on the baking surface in order to avoid damages.**

DON'T USE wet rags or other materials containing dampness. **NEVER THROW** water inside; **IT'S IMPORTANT TO AVOID** strong thermal rushes which could damage the oven.

DONT'S USE SALT INSIDE THE OVEN

The professional ovens VESUVIO have been planned and designed for the cooking of pizza-bread-cookies etc... Refrattari Valoriani s.r.l. declines all responsibility in case of a different use, except for the above mentioned ones.

La Bottega Toscana
www.Pizza-Ofen.de
Export Department